



()

eternity@greencross.com



GMP가
1985 2008 KGMP KGMP 4 GMP ()

(
,) (2010. 12, GMP

, 가
(, 2000)
가

가

, 가
GMP(
, Good Manufacturing Practice)

가
가

GMP 1977 1994 (有效性, efficiency), (安

全性, safety)

(安定性, stability)

가

[1]

	m ³			
	(At Rest)		(In Operation)	
	0.5 μm	5 μm	0.5 μm	5 μm
A	3520	20	3520	20
B	3520	29	352000	2900
C	352000	2900	3520000	29000
D	3520000	29000		

[2]

	cfu/m ³	(90mm) cfu/4 hr	(55mm) cfu/plate	5 가 cfu/glove
A	1	1	1	1
B	10	5	5	5
C	100	50	25	-
D	200	100	50	-

가
가
(Heating Ventilation Air-Conditioning System)

HVAC System

()

1]

[1]

가

(Cooling & Heating)

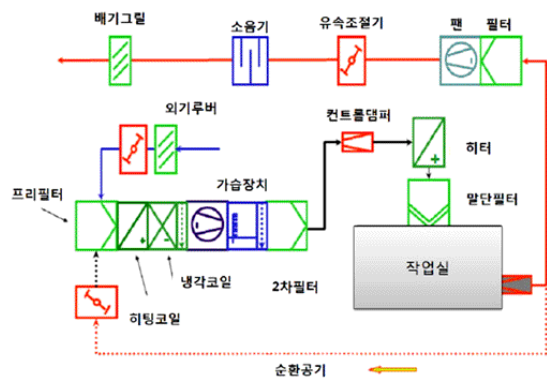
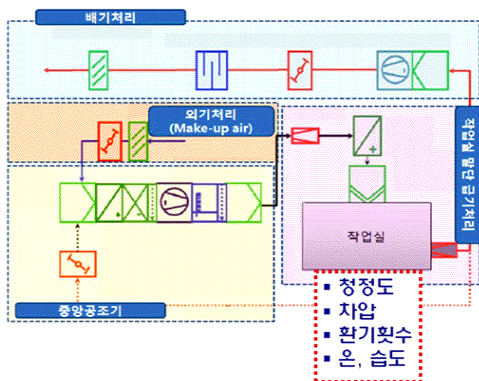

[1] HVAC System

(de-
humidification) 가 (Humidification)
(Purification), (ventilation)

가

가

가

4

가

가

가

100%

가

가

API chemical

- 가

-

-

-

-

UPS

(飛散性)

가

glove box

isolator, powder transfer equipment

가

가 (Heating Coil),

(Cooling

가

Coil)

HEPA

40%

가

가

(20~30%)

가

가
()

가

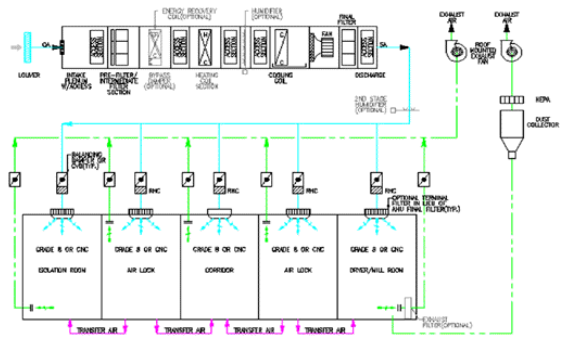

API

가

- 100% (Dust Collect)

가 가

HEPA Filter

- CNC (Controlled Non Classified) Class D

Bubble Type Air

Lock

2.1 Chemical API

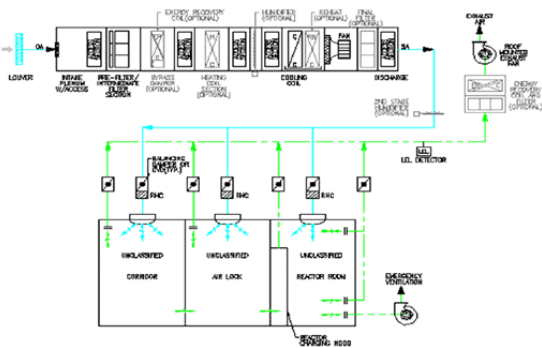

Chemical API

(Active Pharmaceutical Ingredient,)

가

- 100%

API

2.2 (OSD)

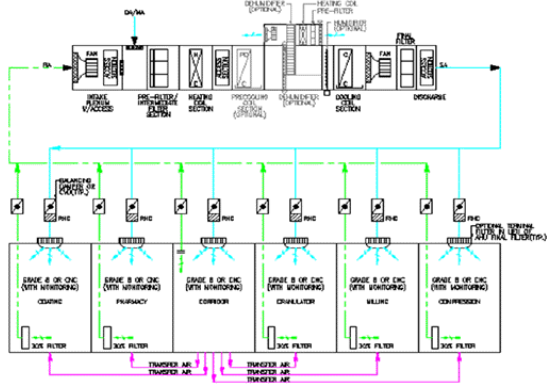

(OSD, Oral Solid Dosage)

가

- (, 100%)
- ()
- HEPA Filter
- CNC(Controlled Non Classified) Class D
- , , ,

2.3 (Sterile Product)

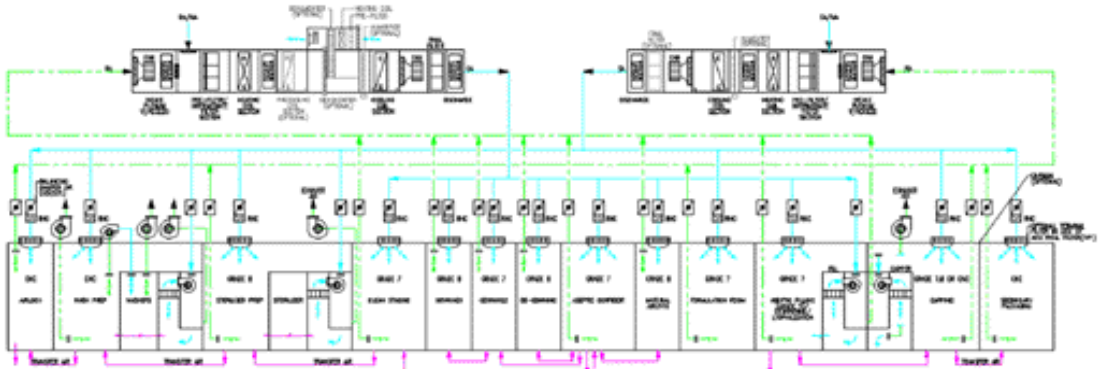

(Sterile Product)

가 .

- (가)
- (Washing Machine, Autoclave)
- HEPA Filter
- CNC (Controlled Non Classified), Class D, Class C, Class B, Class A
-

2.4 (Biopharmaceutical Product)

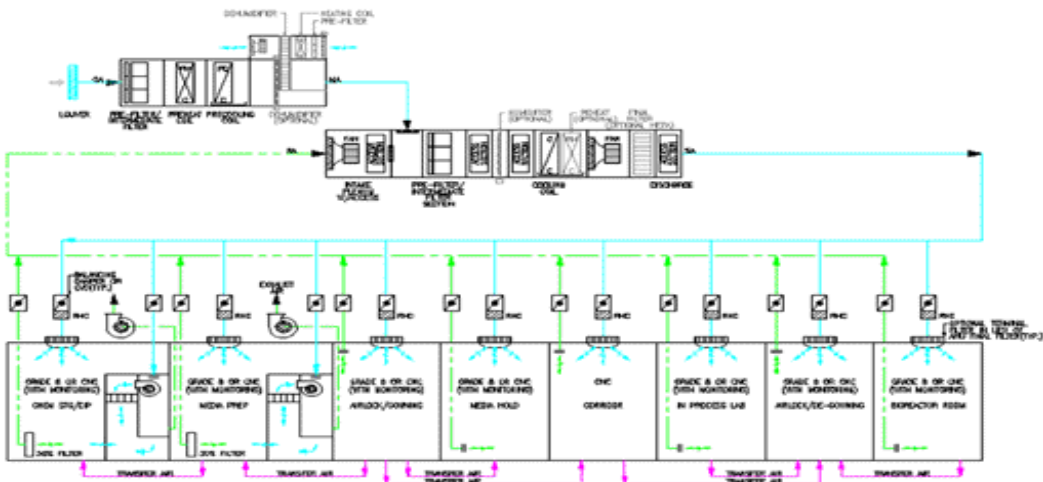

(Biopharmaceutical Product)

가 .

(Pre-AHU)

(가)

(Washing Machine, Autoclave)

HEPA Filter

- CNC(Controlled Non Classified), Class D, Class C, Class B, Class A

2.5 QC (Quality Control Laboratory)

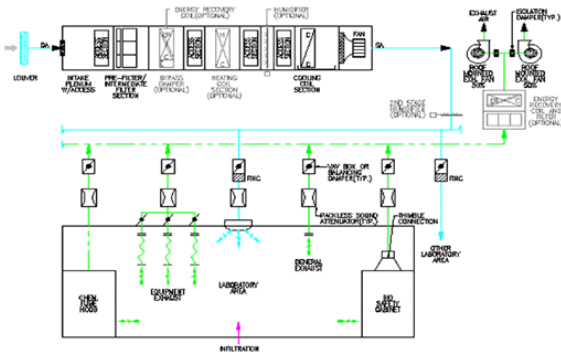

QC (Quality Control Laboratory)

가 .

(가) , Chemical , BSC

2.6 (Dispensing), (Sampling)

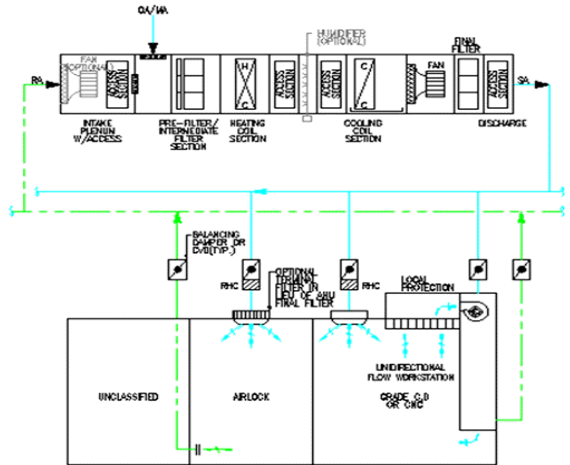

(Dispensing), (Sampling)

가 .

(가)

HEPA Filter

- CNC(Controlled Non Classified), Class D, Class C

(3 -1-

가)

(,) ,)

(

(: 031-260-9434)